



Division of Budzar Industries
38241 Willoughby Parkway
Willoughby, OH 44094
PH: 440-918-0505
FX: 440-918-0606

Shini USA, the plastics division of Budzar Industries, Inc., combines 50 years of in the plastics auxiliary machinery market.

As a global leader in the manufacture of Dryers, Hopper Loaders, Temperature Controllers, Hot Oil Units, Portable Air-Cooled Chillers, Portable Water-Cooled Chillers, Central Chillers, Grinders and Conveyers, Shini USA offers the latest technology.

Our goal of combining the best in worldwide engineering, design and support insures plastic processors the best quality at a maximum value when buying our products.

Shini is one of the worlds leading manufactures that specialize in producing a full range of auxiliary equipment for the plastics industry for over 37 years. At Shini USA, we incorporate local engineering, design and service support to provide maximum value and quality.

All material surfaces are constructed of stainless steel to avoid contamination. The industrial design will stand up to even the harshest operating conditions.

Final assembly and thorough testing of each machine is performed at Shini USA's facility in Willoughby, Ohio. We guarantee that each and every unit will start up with ease and perform with the excellence expected of Shini USA, we stand behind our products 100%.

The listed features are provided as "standard equipment" and exceed other available equipment on the market.



Compressed Air Venturi Hopper Loader

Features Include:

- ◆ Stainless Steel Hopper and Base
- ◆ Low Maintenance Filter Assembly
- ◆ Wide Tube Loader keeps Material Flowing without Bridging
- ◆ Material Demand Sensor
- ◆ Compact and Lightweight
- ◆ Filtered Exhaust
- ◆ Level Sensor in Glass-Tube Signals Material Status
- ◆ Compressed Air Filter and Regulator
- ◆ Quick Release Clamps on Base for Easy Cleaning
- ◆ Adjustable Direction of Hopper and Base

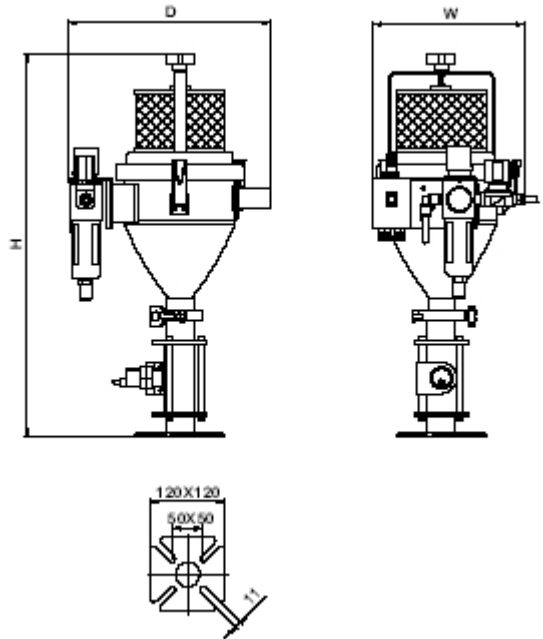

Structural View

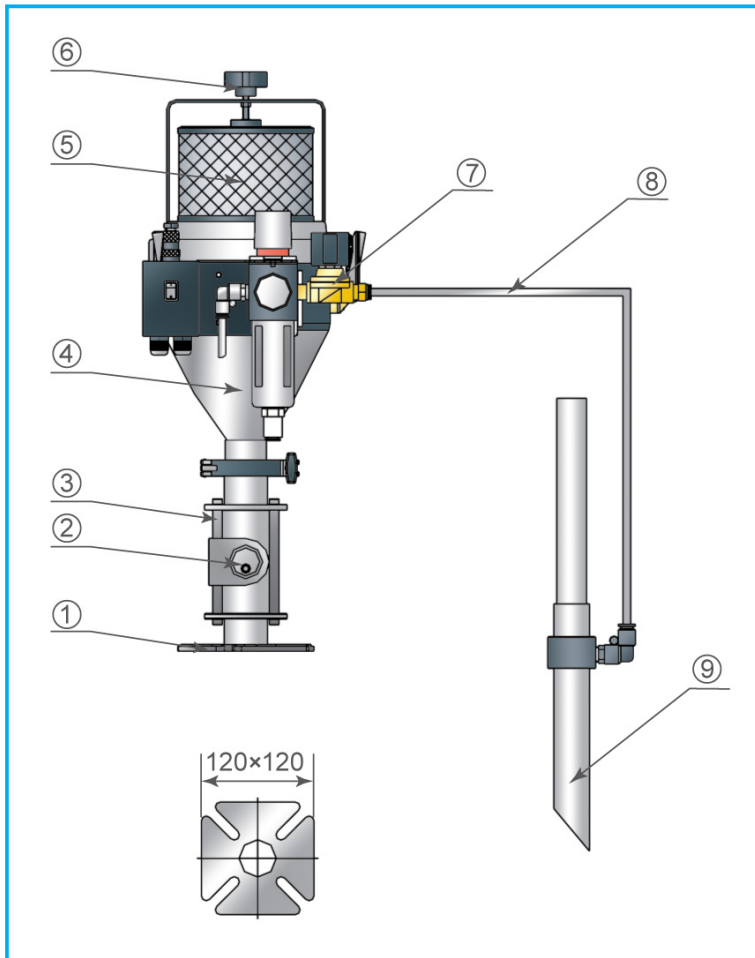

1. Base
2. Sensor
3. Flange connecting pole
4. Hopper
5. Air filter
6. Fixing knob
7. Compressed-air filter、lubricator cap & regulator
8. Air pipe
9. Conveying pipe

Venturi Loader V Series	VL-50
Conveying Capacity	66 lbs
Hopper capacity	½ lbs
Power Supply	110/1/60
Conveying pipe size	1.25"
Dimensions	
Length (inches)	6
Width (inches)	8
Height (inches)	15
Shipping Weight (lbs)	10