

SHINIUSA

**Division of
Budzar Industries**

Shini USA, the plastics division of Budzar Industries, Inc., combines 50 years of in the plastics auxiliary machinery market.

As a global leader in the manufacture of Dryers, Hopper Loaders, Temperature Controllers, Hot Oil Units, Portable Air-Cooled Chillers, Portable Water-Cooled Chillers, Central Chillers, Grinders and Conveyers, Shini USA offers the latest technology.

Our goal of combining the best in worldwide engineering, design and support insures plastic processors the best quality at a maximum value when buying our products.

The grinders are available for sprues, runners, small, medium and large parts with various sized cutting chambers. The staggered blade design provides more cuts per revolution resulting in higher outputs and consistent particle size.



These units are compact and offer easy access to all components. The heavy duty powder coating, industrial duty components and rugged design will stand up to even the harshest operating conditions.

The listed features are provided as "standard equipment" and exceed other available equipment on the market.

Thorough testing of each unit is performed at the Shini USA/Budzar World Alliance facility in **Willoughby, Ohio** to guarantee each and every unit will start up with ease and perform with the excellence expected of Budzar Industries. We stand behind our products 100%.

Sound Proof Central Beside The Press Grinders Staggered Blades

Standard Features

- ◆ Full sound proofed enclosure
- ◆ Power assisted tilt back adjustable hopper with 3 angle positions
- ◆ Reversible screen with dust bag included
- ◆ Blower /cyclone package included
- ◆ Solid rotor pulley
- ◆ Energy efficient operation
- ◆ Staggered rotor design
- ◆ Vacuum bin discharge
- ◆ Emergency stop button
- ◆ Tool free access to drop down screen cradle and rotor
- ◆ High amp alarm and amp meter
- ◆ Hardened cutting chamber
- ◆ Hardened cutting knives
- ◆ Safety interlocks
- ◆ Motor overload relays
- ◆ Cutting blade retainer for quick blade changing
- ◆ Outboard sealed bearings
- ◆ Staggered blade design
- ◆ 3 – year electrical warranty



Cutting blades

Model	HP	Cutting Chamber	Conveying Blower-HP	Cutting Blades	Blade Type	Rotating Blades	Throuput LBS/HR
SG-2324	9	9 x 9.4"	1	2	Staggered	3 x 2	230
SG-2336	12	9 x 14.2"	1	2	Staggered	3 x 3	310
SG-2348	18	9 x 19"	1	2	Staggered	3 x 4	400
SG-3060	25	12 x 24"	1	2	Staggered	3 x 5	550
SG-3060H	30	12 x 24"	1	2	Staggered	3 x 5	900

Dimensions

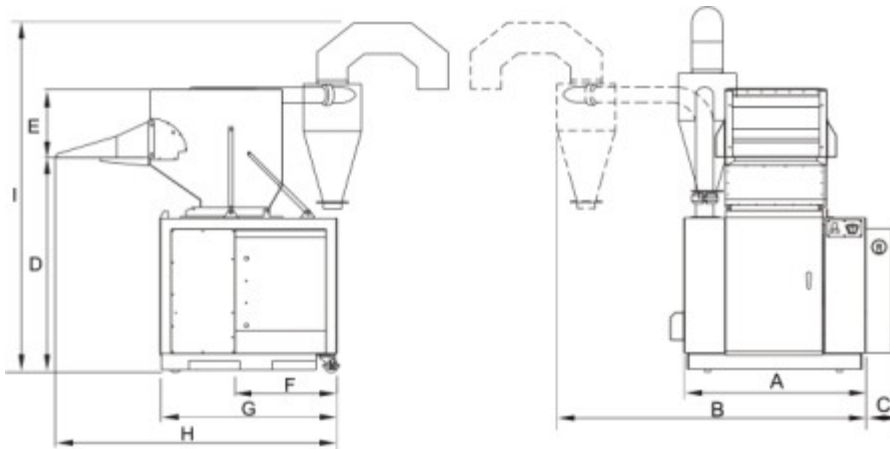

	SG-2324	SG-2336	SG-2348	SG-3060	SG-3060H
A	30"	35"	39.5"	44"	44"
B	57.5"	62"	67"	71.6"	71.6"
C	7.5"	7.5"	7.5"	7.5"	7.5"
D	45.2"	45.2"	45.2"	49"	49"
E	12"	12"	12"	14.7"	14.7"
F	20"	20"	20"	22"	22"
G	35.2"	35.2"	35.2"	38.3"	38.3"
H	53"	53"	53"	59.4"	59.4"
I	64"	64"	64"	73"	73"
Weight (lbs)	915	1000	1110	1300	1400