



Shini USA, the plastics division of Budzar Industries, Inc., combines 50 years of in the plastics auxiliary machinery market.

As a global leader in the manufacture of Dryers, Hopper Loaders, Temperature Controllers, Hot Oil Units, Portable Air-Cooled Chillers, Portable Water-Cooled Chillers, Central Chillers, Grinders and Conveyers, Shini USA offers the latest technology.

Our goal of combining the best in worldwide engineering, design and support insures plastic processors the best quality at a maximum value when buying our products.

Just to give you some back ground, Shini Plastic Technologies is one of the worlds leading manufactures that specialize in producing a full range of auxiliary equipment for the **plastics industry** the last 37 years. At Shini USA, we incorporate local engineering, design and service support to provide maximum value and quality.

The grinders are available for sprues, runners, small, medium and large parts with various sized cutting chambers. The staggered blade design provides more cuts per revolution resulting in higher outputs and consistent particle size. Integrated safety interlocks and an emergency E-stop are included as standard features.

A tilt back hopper and screen are designed for easy cleaning and maintenance with the need for tools.

These units are compact and offer easy access to all components. The heavy duty powder coating, industrial duty components and rugged design will stand up to even the harshest operating conditions. The listed features are provided as "standard equipment" and exceed other available equipment on the market.

Thorough testing of each unit is performed in **Willoughby, Ohio** to guarantee each and every unit will start up with ease and perform with the excellence expected Budzar Industries. We stand behind our products 100%.



Low Speed Grinders

Standard Features:

- ◆ Sound proofed hopper
- ◆ Caster mounted
- ◆ Harden cutting chamber
- ◆ Low RPM motor Gear driven, high efficiency and low speed for low noise and low energy consumption and less dust
- ◆ Tilt back hopper
- ◆ Drop down screen cradle
- ◆ Reversible screen
- ◆ Safe easy access for cleaning and maintenance with out tools
- ◆ Staggered blades
- ◆ Hardened cassette knives
- ◆ Integrated safety interlocks
- ◆ Regrind bin with vacuum take off probe
- ◆ Emergency E-Stop
- ◆ Obstruction alarm – When blockage occurs



Staggered cutting Blade design

Dimensions

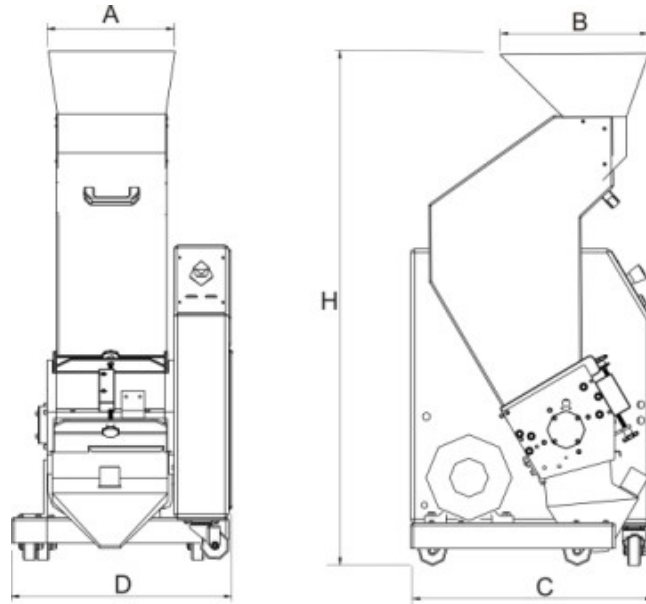

Model	SG-1621H	SG-1628S	SG-2028C	SG-1628H	SG-1635	SG-1635H	SG-2042CH	SG-2042C
A	13"	16"	16.5"	16"	18.5"	18.5"	22"	22"
B	15"	15"	16.5"	15"	15"	15"	16.5"	16.5"
C	24"	24"	27.5"	24"	24"	24"	27.5"	27.5"
D	19"	20"	20"	20"	24.5"	24.5"	23.6"	23.6"
H	51"	51"	51.25"	51"	51"	51"	51.25"	51.25"
Weight (lbs)	385	420	500	420	450	485	630	600